

A

B

C

D

A

B

C

D

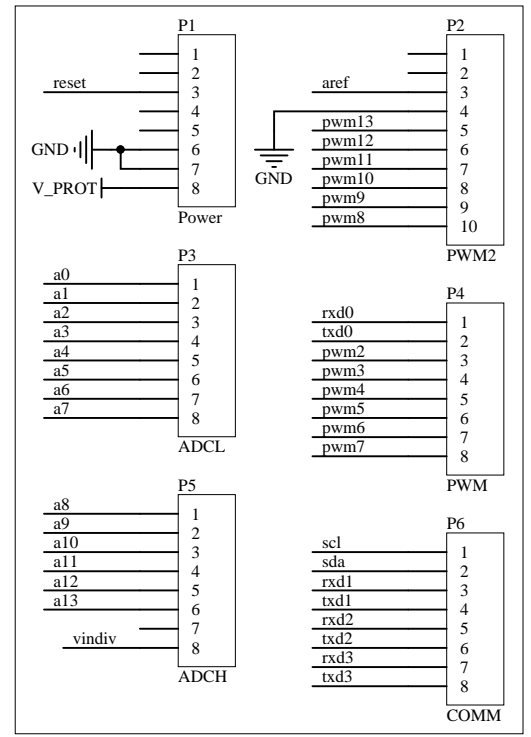
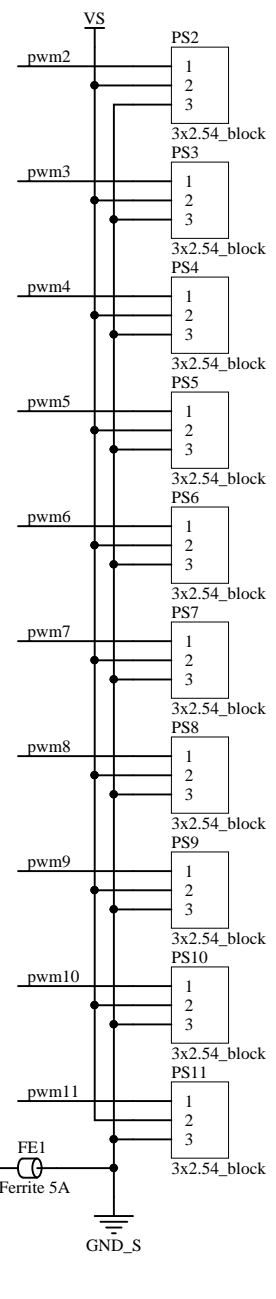
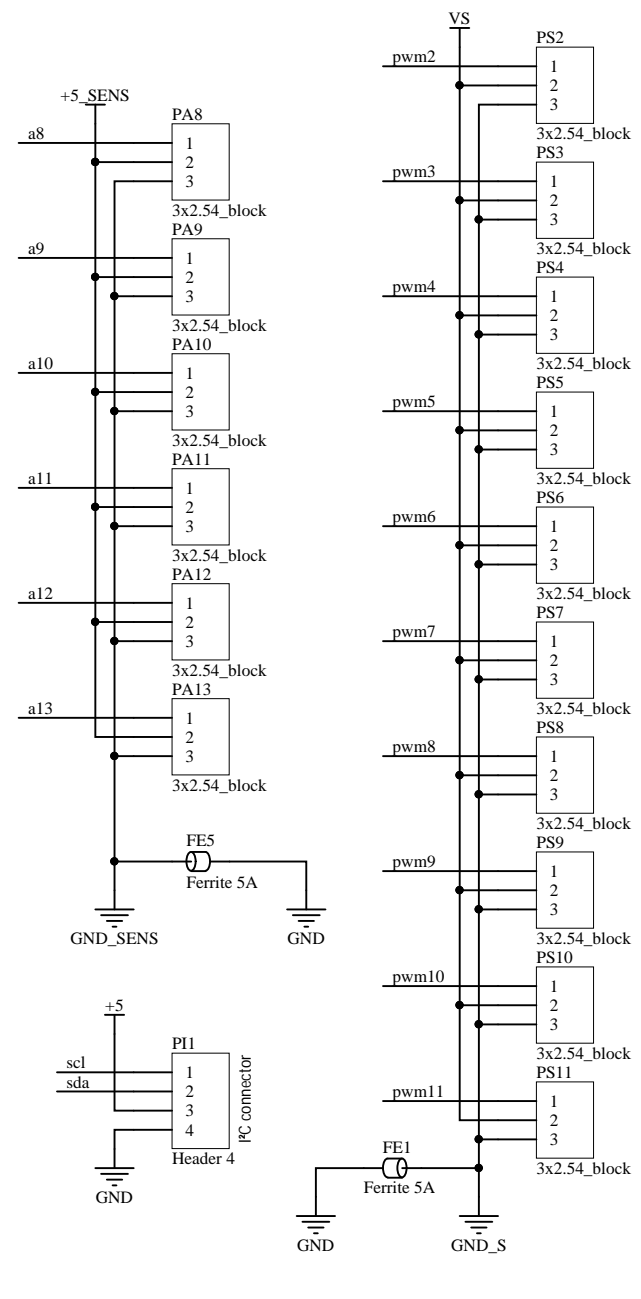
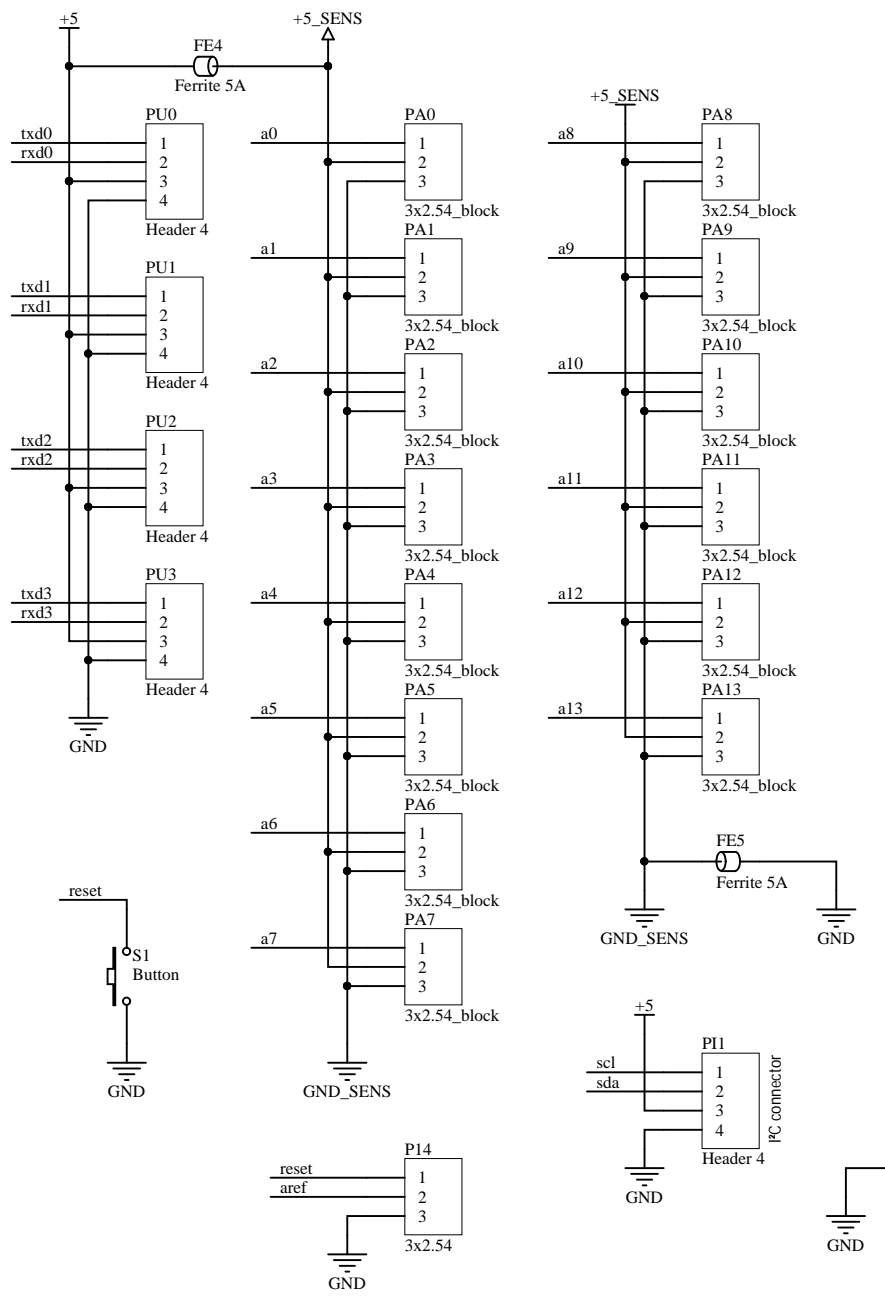

Arduino Mega 2560 R3 connectors

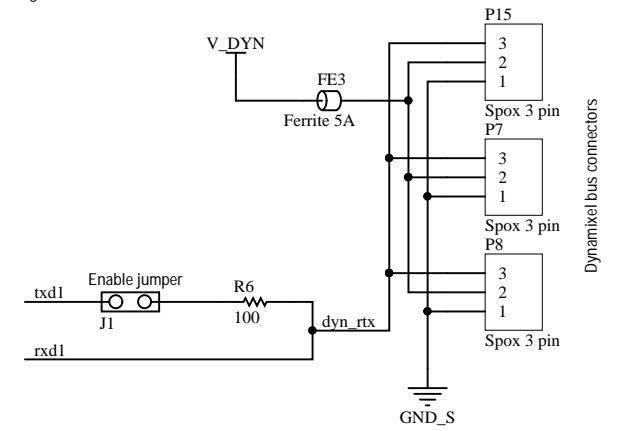

Dynamixel bus connectors

Title Arduone for Arduino Mega 2560			Alessandro Crespi BioRob/EPFL		
Size: A4	Number: 1	Revision: 2			
Date: 16.5.2018	Time: 17:43:44	Sheet 1 of 2			
File: Z:\DXP\CR\arduone.SchDoc					

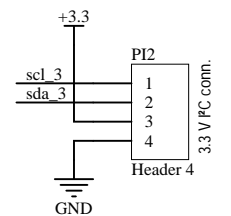
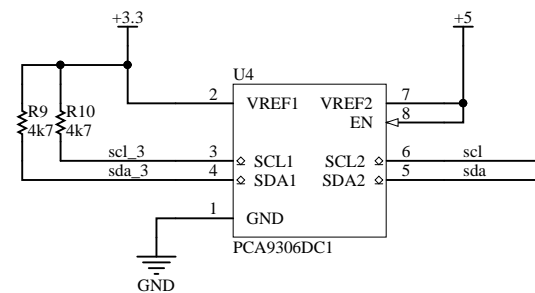
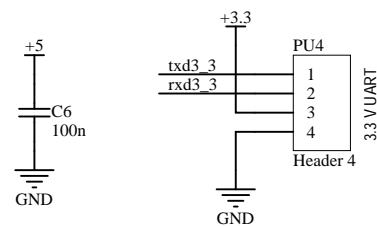
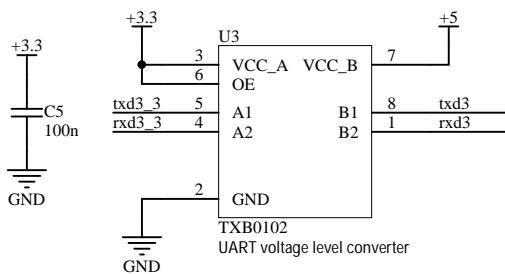
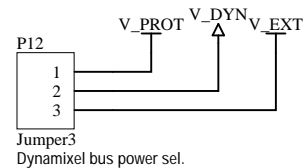
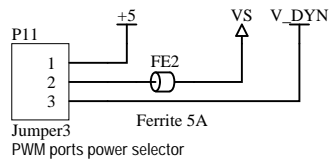
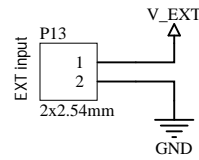
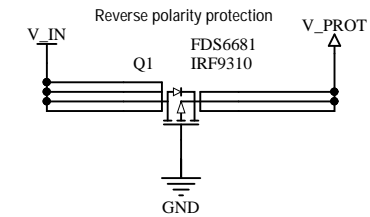
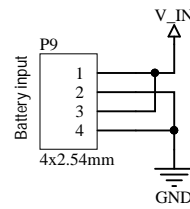
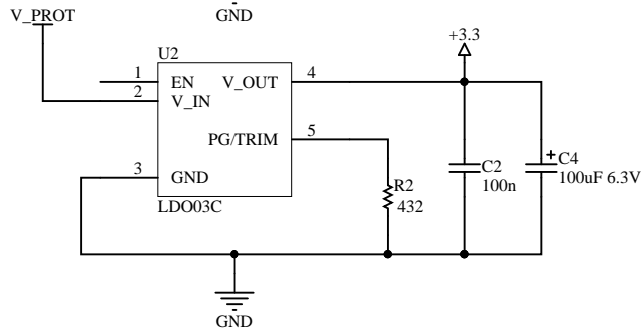
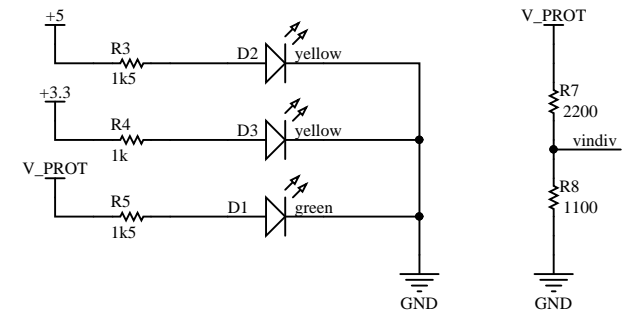
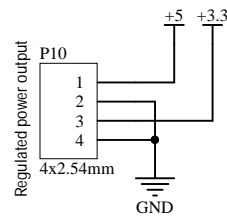
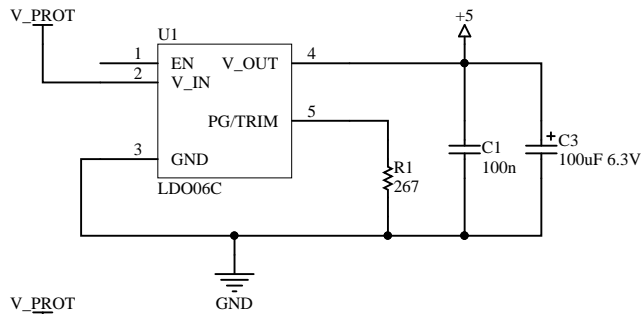

Title Arduone for Arduino Mega 2560		
Size: A4	Number: 1	Revision: 2
Date: 16.5.2018	Time: 17:43:44	Sheet 2 of 2
File: Z:\DXP\CR\arduone2.SchDoc		

Alessandro Crespi
BioRob/EPFL



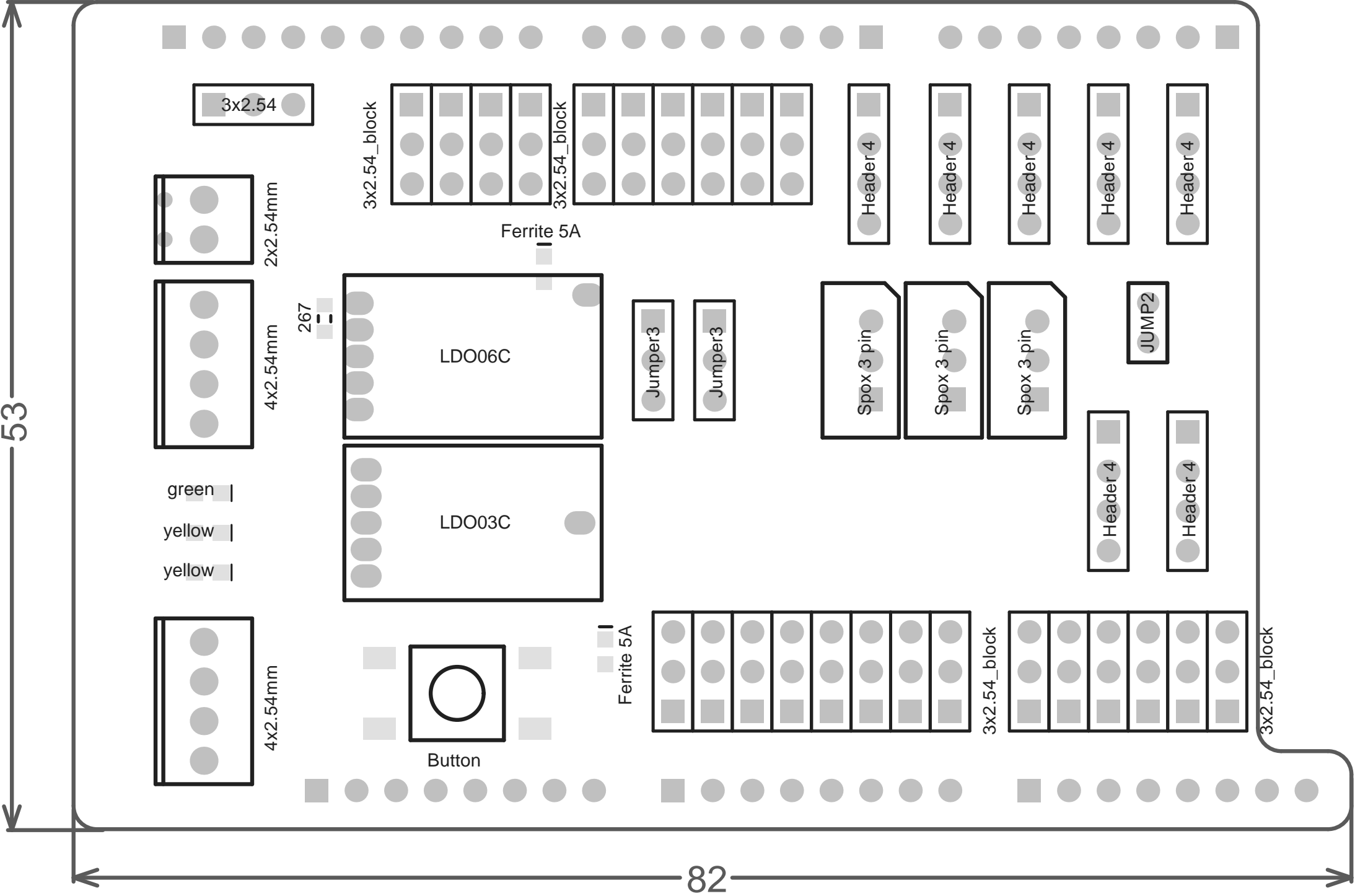

COMM

PWM

PWM2

PCA9306DC1



100

4k7
4k7

TXB0102

100nF

100nF

Ferrite 5A

Ferrite 5A

100nF

100uF 6.3V

IRF9393

432

1k5

1k5

1k

Ferrite 5A

1100

2200

ADCH

ADCL

Power